

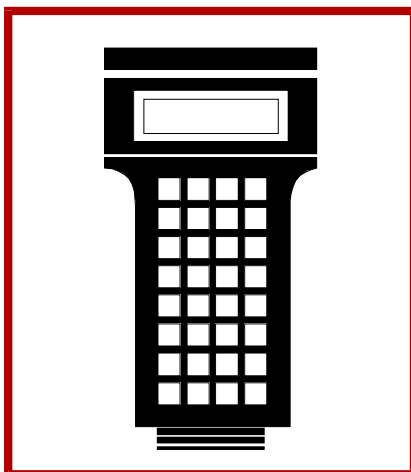

Instruction

Plant Loop to Computer Interface (INPCI01)

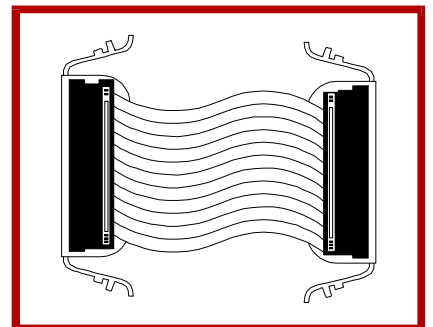
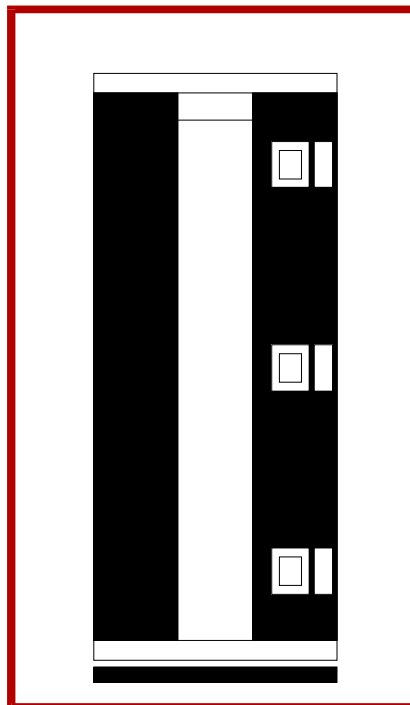
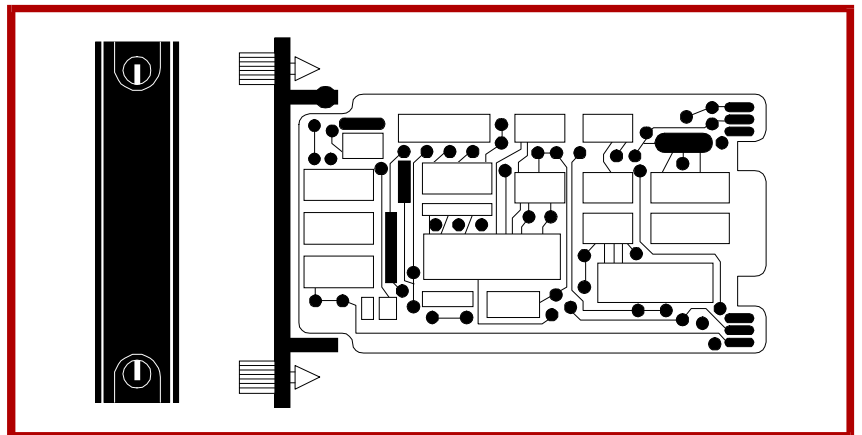

WARNING notices as used in this instruction apply to hazards or unsafe practices that could result in personal injury or death.

CAUTION notices apply to hazards or unsafe practices that could result in property damage.

NOTES highlight procedures and contain information that assists the operator in understanding the information contained in this instruction.

WARNING

INSTRUCTION MANUALS

DO NOT INSTALL, MAINTAIN, OR OPERATE THIS EQUIPMENT WITHOUT READING, UNDERSTANDING, AND FOLLOWING THE PROPER **Elsag Bailey** INSTRUCTIONS AND MANUALS; OTHERWISE, INJURY OR DAMAGE MAY RESULT.

RADIO FREQUENCY INTERFERENCE

MOST ELECTRONIC EQUIPMENT IS INFLUENCED BY RADIO FREQUENCY INTERFERENCE (RFI). CAUTION SHOULD BE EXERCISED WITH REGARD TO THE USE OF PORTABLE COMMUNICATIONS EQUIPMENT IN THE AREA AROUND SUCH EQUIPMENT. PRUDENT PRACTICE DICTATES THAT SIGNS SHOULD BE POSTED IN THE VICINITY OF THE EQUIPMENT CAUTIONING AGAINST THE USE OF PORTABLE COMMUNICATIONS EQUIPMENT.

POSSIBLE PROCESS UPSETS

MAINTENANCE MUST BE PERFORMED ONLY BY QUALIFIED PERSONNEL AND ONLY AFTER SECURING EQUIPMENT CONTROLLED BY THIS PRODUCT. ADJUSTING OR REMOVING THIS PRODUCT WHILE IT IS IN THE SYSTEM MAY UPSET THE PROCESS BEING CONTROLLED. SOME PROCESS UPSETS MAY CAUSE INJURY OR DAMAGE.

AVERTISSEMENT

MANUELS D'OPÉRATION

NE PAS METTRE EN PLACE, RÉPARER OU FAIRE FONCTIONNER L'ÉQUIPEMENT SANS AVOIR LU, COMPRIS ET SUIVI LES INSTRUCTIONS RÉGLEMENTAIRES DE **Elsag Bailey**. TOUTE NÉGLIGENCE À CET ÉGARD POURRAIT ÊTRE UNE CAUSE D'ACCIDENT OU DE DÉFAILLANCE DU MATÉRIEL.

PERTURBATIONS PAR FRÉQUENCE RADIO

LA PLUPART DES ÉQUIPEMENTS ÉLECTRONIQUES SONT SENSIBLES AUX PERTURBATIONS PAR FRÉQUENCE RADIO. DES PRÉCAUTIONS DEVRONT ÊTRE PRISES LORS DE L'UTILISATION DU MATÉRIEL DE COMMUNICATION PORTATIF. LA PRUDENCE EXIGE QUE LES PRÉCAUTIONS À PRENDRE DANS CE CAS SOIENT SIGNALÉES AUX ENDROITS VOULUS DANS VOTRE USINE.

PERTURBATIONS DU PROCÉDÉ

L'ENTRETIEN DOIT ÊTRE ASSURÉ PAR UNE PERSONNE QUALIFIÉE EN CONSIDÉRANT L'ASPECT SÉCURITAIRE DES ÉQUIPEMENTS CONTRÔLÉS PAR CE PRODUIT. L'AJUSTEMENT ET/OU L'EXTRACTION DE CE PRODUIT PEUT OCCASIONNER DES À-COUPS AU PROCÉDÉ CONTRÔLE LORSQU'IL EST INSÉRÉ DANS UNE SYSTÈME ACTIF. CES À-COUPS PEUVENT ÉGALEMENT OCCASIONNER DES BLESSURES OU DES DOMMAGES MATÉRIELS.

NOTICE

The information contained in this document is subject to change without notice.

Elsag Bailey, its affiliates, employees, and agents, and the authors and contributors to this publication specifically disclaim all liabilities and warranties, express and implied (including warranties of merchantability and fitness for a particular purpose), for the accuracy, currency, completeness, and/or reliability of the information contained herein and/or for the fitness for any particular use and/or for the performance of any material and/or equipment selected in whole or part with the user of/or in reliance upon information contained herein. Selection of materials and/or equipment is at the sole risk of the user of this publication.

This document contains proprietary information of Elsag Bailey, Elsag Bailey Process Automation, and is issued in strict confidence. Its use, or reproduction for use, for the reverse engineering, development or manufacture of hardware or software described herein is prohibited. No part of this document may be photocopied or reproduced without the prior written consent of Elsag Bailey.

Preface

The Plant Loop to Computer Interface (INPCI01) enables two way communication between a computer and INFI 90 PCUs on a Plant Loop. The three INFI 90 modules that make up the INPCI01 are: the Loop Interface Module (INLIM03), Point Table Module (INPTM01), and Serial Interface Module (INSIM01).

This instruction explains INPCI01 features, specifications, and operation. It also includes installation and troubleshooting procedures for the interface.

The system engineer or technician using the INPCI01 should read and understand this instruction before installing the interface modules. In addition, a complete understanding of the INFI 90 system is beneficial to the user.

List of Effective Pages

Total number of pages in this instruction is 40, consisting of the following:

Page No.	Change Date
Preface	Original
List of Effective Pages	Original
iii through vii	Original
1-1 through 1-5	Original
2-1 through 2-2	Original
3-1 through 3-11	Original
4-1 through 4-3	Original
5-1 through 5-5	Original
6-1	Original
7-1	Original
8-1	Original
A-1 through A-2	Original
B-1 through B-2	Original

When an update is received, insert the latest changed pages and dispose of the superseded pages.

NOTE: On an update page, the changed text or table is indicated by a vertical bar in the outer margin of the page adjacent to the changed area. A changed figure is indicated by a vertical bar in the outer margin next to the figure caption. The date the update was prepared will appear beside the page number.

Safety Summary

**GENERAL
WARNINGS****Equipment Environment**

All components, whether in transportation, operation, or storage must be in a noncorrosive environment.

Electrical Shock Hazard During Maintenance

Disconnect power or take precautions to insure that contact with energized parts is avoided when servicing.

Special Handling

This module uses Electrostatic Sensitive Devices (ESD).

**SPECIFIC
WARNINGS**

Disconnect power before installing dipshunts for slave modules on the MMU backplane (slave expander bus). Failure to do so could result in severe or fatal shock. (p. 3-10)

**SPECIFIC
CAUTIONS**

Ensure that the cable end marked J1 is connected to P1 on the NICL01, and J2 is connected to the LIM. Failure to do so could result in module damage (see Figure B-1). (p. B-1)

Sommaire de Sécurité

**AVERTISSEMENT
D'ORDRE
GENERAL**

Environnement de l'équipement

Ne pas soumettre les composants à une atmosphère corrosive lors du transport, de l'entreposage ou de l'utilisation.

Risques de chocs électriques lors de l'entretien

S'assurer de débrancher l'alimentation ou de prendre les précautions nécessaires à éviter tout contact avec des composants sous tension lors de l'entretien.

Précautions de manutention

Ce module contient des composants sensibles aux décharges électro-statiques.

**AVERTISSEMENT
D'ORDRE
SPECIFIQUE**

Couper l'alimentation avant d'installer les dipshunts sur la plaque arrière du châssis de montage de modules (MMU). Toute négligence à cet égard constitue un risque de choc pouvant entraîner des blessures graves, voire mortelles. (p. 3-10)

**ATTENTION D'ORDRE
SPECIFIQUE**

S'assurer que l'extrémité identifiée par J1 est reliée à P1 du module NICL01 et que J2 est reliée au module LIM. Sinon, les modules pourraient être endommagés (voir la figure B-1). (p. B-1)

Table of Contents

	<i>Page</i>
SECTION 1 - INTRODUCTION	1-1
OVERVIEW	1-1
INTENDED USER	1-2
INTERFACE DESCRIPTION	1-2
Serial Interface Module	1-2
Loop Interface Module	1-2
Point Table Module	1-2
FEATURES	1-2
INSTRUCTION CONTENT	1-3
HOW TO USE THIS MANUAL	1-3
GLOSSARY OF TERMS AND ABBREVIATIONS	1-4
REFERENCE DOCUMENTS	1-4
NOMENCLATURE	1-5
SPECIFICATIONS	1-5
SECTION 2 - DESCRIPTION AND OPERATION	2-1
INTRODUCTION	2-1
INTERFACE OPERATION	2-1
Loop Interface Module INLIM03	2-1
Point Table Module INPTM01	2-2
Serial Interface Module INSIM01	2-2
SECTION 3 - INSTALLATION	3-1
INTRODUCTION	3-1
SPECIAL HANDLING	3-1
UNPACKING AND INSPECTION	3-1
INSIM01 SWITCH SETTINGS	3-2
Option Switch (SW2)	3-2
Port Option Switch Settings (SW3 and SW4)	3-3
ROM Jumpers	3-4
Bypass Options (JP3 to JP6)	3-5
Communication Rate (JP9 and JP10)	3-6
INLIM03 SWITCH SETTINGS	3-6
INPTM01 SWITCH SETTINGS	3-9
TERMINATION UNIT (MODULE) CONFIGURATION AND INSTALLATION	3-10
INSTALLING THE INTERFACE MODULES	3-10
Installing the INSIM01	3-10
Installing the INLIM03 and INPTM01	3-11
SECTION 4 - OPERATING PROCEDURES	4-1
INTRODUCTION	4-1
INTERFACE START-UP	4-1
SERIAL INTERFACE MODULE LEDs	4-1
LOOP INTERFACE MODULE LEDs	4-2
POINT TABLE MODULE LED	4-3

Table of Contents (continued)

	<i>Page</i>
SECTION 5 - TROUBLESHOOTING	5-1
INTRODUCTION	5-1
EVENT AND ERROR COUNTERS	5-1
MODULE STATUS BYTES	5-1
DIAGNOSTIC TERMINAL	5-1
ECHO TEST	5-2
INTERFACE CHECKOUT PROCEDURE	5-3
SECTION 6 - MAINTENANCE	6-1
INTRODUCTION	6-1
MAINTENANCE SCHEDULE	6-1
SECTION 7 - REPAIR/REPLACEMENT PROCEDURES	7-1
INTRODUCTION	7-1
MODULE REPAIR/REPLACEMENT	7-1
SECTION 8 - SUPPORT SERVICES	8-1
INTRODUCTION	8-1
REPLACEMENT PARTS AND ORDERING INFORMATION	8-1
TRAINING	8-1
TECHNICAL DOCUMENTATION	8-1
APPENDIX A - TERMINATION UNIT (NTCL01) CONFIGURATION	A-1
INTRODUCTION	A-1
APPENDIX B - TERMINATION MODULE (NICL01) CONFIGURATION	B-1
INTRODUCTION	B-1

List of Figures

<i>No.</i>	<i>Title</i>	<i>Page</i>
1-1.	The INPCI01 within the INFI 90 Hierarchy	1-1
2-1.	Functional Diagram of the INPCI01 Modules	2-1
3-1.	Switch and Jumper Locations on the SIM	3-2
3-2.	Jumper Settings for Communication Rates	3-6
3-3.	LIM Switch Locations	3-6
3-4.	PTM Switch (SW1) Location	3-9
4-1.	SIM Faceplate	4-1
4-2.	SIM LED Sequence	4-2
4-3.	LIM Faceplate	4-2
4-4.	PTM Faceplate	4-3
A-1.	NTCL01 Termination Unit and Terminal Assignments	A-2
B-1.	Typical Twinax Cable Connection for the NICL01	B-2

List of Tables

<i>No.</i>	<i>Title</i>	<i>Page</i>
3-1.	Option Switch (SW2) Settings	3-2
3-2.	Diagnostic Port Options (SW3)	3-3
3-3.	Computer Port Options (SW4)	3-4
3-4.	ROM Compatibility (JP1 and JP2)	3-5
3-5.	Bypass Options.....	3-5
3-6.	LIM Event Counter Addresses (SW1)	3-7
3-7.	LIM Error Counter Addresses (SW1)	3-7
3-8.	LIM Node Address Setting (SW2)	3-8
3-9.	PTM Options (SW1)	3-9
4-1.	PTM Status LEDs States	4-3
5-1.	LIM Edge Connector P3 Pin Assignments	5-5
5-2.	PTM Edge Connector P1 Pin Assignments	5-5
5-3.	SIM Board Edge Connector P3 Pin Assignments	5-5
6-1.	Maintenance Schedule	6-1
A-1.	NTCL01 Terminal Assignments	A-1
A-2.	NTCL01 BNC Assignments	A-1
A-3.	Jumper Settings and Cable Types	A-2
B-1.	NICL01 Terminal Assignments	B-1
B-2.	NICL01 BNC Assignments	B-1
B-3.	Jumper Settings and Cable Types	B-2

SECTION 1 - INTRODUCTION

OVERVIEW

The Plant Loop to Computer Interface (INPCI01) is a communication interface that enables a computer to communicate with modules on an INFI 90 Plant Loop. Three modules make up the interface. The Loop Interface Module (INLIM03) handles the module bus to Plant Loop communication transfer. The Point Table Module (INPTM01) does report routing, interprets commands to and from the computer and holds point tables (data storage). The Serial Interface Module (INSIM01) provides an RS-232-C interface to the computer. It translates information from the computer and sends it to the PTM on the module bus. Figure 1-1 shows an example of the INPCI01 within the INFI 90 hierarchy.

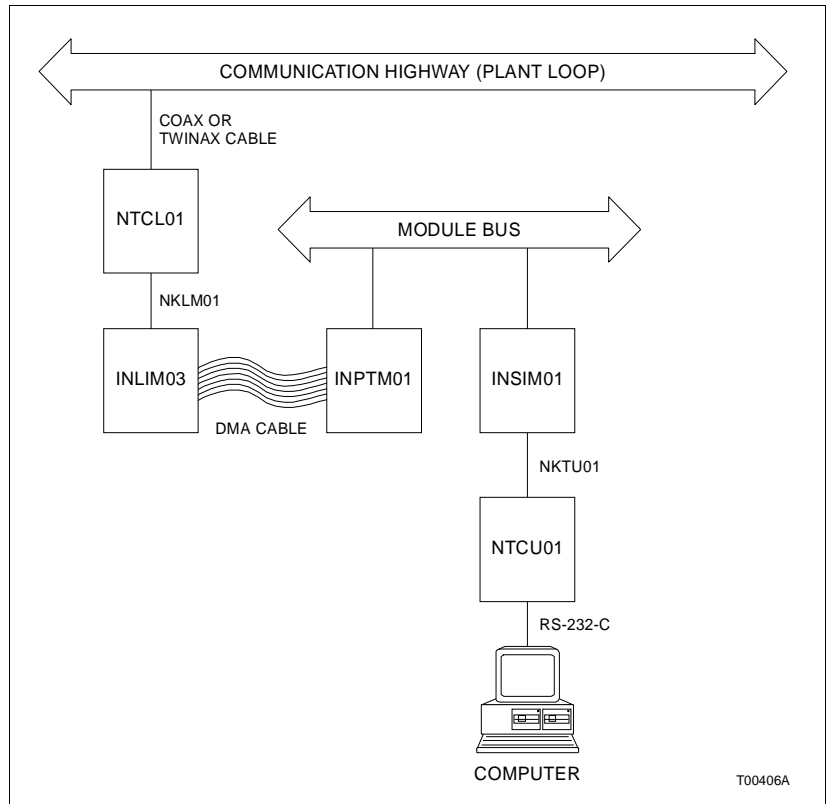

Figure 1-1. The INPCI01 within the INFI 90 Hierarchy

INTENDED USER

System engineers and technicians should read this manual before installing and operating the INPCI01. Refer to the Table of Contents to find specific information after the module is operating.

INTERFACE DESCRIPTION

The Plant Loop to Computer Interface enables a host computer to communicate with any node on the Plant Loop. INPCI01 software enables the computer to acquire data, do process monitoring, load control strategies and configure modules.

This interface is made up of three INFI 90 Communication Modules. The Serial Interface Module provides two RS-232-C ports. The Loop Interface Module provides a serial interface to the Plant Loop. The Point Table Module transfers information from the Plant Loop to the module bus and coordinates interaction between the LIM and SIM.

Serial Interface Module

This module provides an RS-232-C communication port for a host computer and an RS-232-C diagnostic port. By design, this module acts as an RS-233-C type Z interchange, which is a non-specified optional interchange. Jumpers on board the SIM circuit board setup the use of signal lines on the RS-232-C port.

Loop Interface Module

The Loop Interface Module handles the Plant Loop communication protocol. This module buffers and processes all incoming and outgoing messages. Messages are formatted with source/destination addresses, header data, circulation count, message class, data, and cyclic redundancy checks (CRC).

Point Table Module

This module joins the SIM and LIM and does report routing. It also interprets messages from the Plant Loop, interprets commands from the computer, and stores data values in point tables.

FEATURES

This interface provides a plant operator with continuous communication to and from the Plant Loop, through a computer. The INPCI01 protects both the Infi 90 Plant Loop and computer by buffering the two communication protocols. Through the INPCI01 software, the computer can read station variables, values of function blocks, and module status (through module exception reports). The computer can set station variables and mode, set logic switches, and report values to modules and Operator Interface Stations (OIS) configured to read them.

Process inputs and outputs are kept in point tables. The computer can pass data by point number or bypass the point table and demand data directly from any PCU. The computer can poll the point table or request on points whose values have changed. The user can load INFI 90 modules with control strategies from the computer without affecting the point table.

INSTRUCTION CONTENT

This manual consists of eight sections.

Introduction	Is an overview of the INPCI01. It contains module description, features and specifications.
Description and Operation	Explains the module operation.
Installation	Covers handling guidelines and explains how to set up the user-configured switches before placing it in operation.
Operating Procedures	Provides information about normal operation.
Troubleshooting	Explains how to troubleshoot the module using error codes and lists the corrective action.
Maintenance	Contains a maintenance schedule for the slave module.
Repair/Replacement Procedures	Explains how to replace the PCI modules.
Support Services	Explains the customer training Bailey Controls Company provides and information about ordering replacement parts.

HOW TO USE THIS MANUAL

Read this manual in sequence. It is important to become familiar with the entire contents of this manual before using the PCI. The organization of this manual enables the user to find needed information quickly.

1. Read and do the steps in **Section 3**.
2. Read **Section 4** thoroughly before powering up the station.
3. Refer to **Section 5** if a problem occurs.
4. Refer to **Section 6** for scheduled maintenance requirements.
5. Use **Section 8** for a list of replacement parts and warranty information.

GLOSSARY OF TERMS AND ABBREVIATIONS

Term	Definition
DCE	Data Circuit-Terminating Equipment - The termination point of a communication circuit such as a line driver or modem.
DTE	Data Terminal Equipment - End-user machine of a communication circuit such as a terminal or computer.
Checksum	1. The sum of bytes in a message except the checksum byte itself. 2. The sum of bytes in the firmware except the checksum byte itself. This sum is used in firmware security checks.
CRC	Cyclic Redundancy Check code - A unique code calculated from a data string and compared every time that string is checked. If a mismatch is found, an error is generated. This code is at the end of every PCI message.
Exception Report	Information update generated when a point change is greater than a specified significant amount; abbreviated as XR.
Frame	Valid string of bytes on the Plant Loop or INFI-NET ring.
MMU	Module Mounting Unit - a card cage that provides electrical and communication support for INFI 90 modules.
PCI	Plant Loop to Computer Interface (INPCI01/02) - A communication interface providing configuration and control of the Plant Loop through a host computer.
PCU	Process Control Unit - rack type industrial cabinet that contains master, slave and communication modules, and their communication paths.
Node	Device(s) on the INFI 90/NETWORK 90 Plant Loop, Superloop or INFI-NET (maximum of 63 on Plant Loop, 250 on Superloop or INFI-NET). A node can be a Management Command System (MCS), Operator Interface Station (OIS), a Process Control Unit (PCU) containing modules or any INFI-NET Communication Interface.
TM	Termination Module - Provides input/output connection between plant equipment and the INFI 90/NETWORK 90 process modules. The termination module is a flat circuit board for panel mounting.
TU	Termination Unit - Provides input/output connection between plant equipment and the INFI 90/NETWORK 90 process modules. The termination unit is a flat circuit board for panel mounting.

REFERENCE DOCUMENTS

The documents listed below provide additional information for related hardware/software. Refer to these as needed.

Document No.	Document
I-E96-110	Operator Interface Station
I-E96-611	Loop Interface/Bus Interface Module
I-E96-621	Plant Loop to Computer Interface (INPCI02)
I-E93-900-20	Function Code Applications Manual
I-E93-905-9	Enhanced CIU Programmer's Reference Manual
I-E93-911	Termination Unit Manual

NOMENCLATURE

The related hardware is used with the Plant Loop to Computer Interface.

Nomenclature	Description
IEMMU01/02	Module Mounting Unit
NFTP01	Field Termination Panel
NICL01	Communication Termination Module
NKLS03	NTCL01 to INLIM03 Cable
NKLS04	NICL01 to INLIM03 Cable
NKTU01	NTCU01 to INSIM01 Cable
NTCU01	Computer Interface Termination Unit
NTCL01	Communication Termination Unit
NTMU01	Termination Mounting Unit

SPECIFICATIONS

GENERAL	
Ports	Two EIA Standard RS-232-C port on the INSIM01.
Communication Rate	300; 1,200; 2,400; 9,600 or 19,200 baud (user-selectable).
Point Capacity	511 points per INPCI01.
Throughput	Effective 1-second scan class points based upon 150 exception reports per second.
POWER REQUIREMENTS	
INLIM03	+ 5 VDC at 2.0 A (10 Watts) nominal. ±15 VDC at 80 mA (1.2 Watts) nominal.
INPTM01	+ 5 VDC at 1.0 A (5 Watts) nominal. + 15 VDC at 150 mA (2.25 Watts) nominal. - 15 VDC at 120 mA (1.80 Watts) nominal.
INSIM01	+ 5 VDC at 1.92 A (10 Watts) maximum. + 15 VDC at 35 mA (0.53 Watts) maximum. - 15 VDC at 28 mA (0.42 Watts) maximum.
ENVIRONMENTAL	
Electromagnetic/Radio Frequency Interference	Values are not available at this time. Keep cabinet doors closed. Do not use communication equipment any closer than 2 meters from the cabinet.
Ambient Temperature	0° to 70°C (32° to 158°F)
Relative Humidity	0 to 95% up to 55°C (131°F) (non-condensing) 0 to 45% at 70°C (158°F) (non-condensing)
Atmospheric Pressure	Sea level to 3 km. (1.86 miles)
Air Quality	Noncorrosive
CERTIFICATION	All INPCI01 modules have been individually CSA certified for use as process control equipment in an ordinary (non-hazardous) environment.

SPECIFICATIONS SUBJECT TO CHANGE WITHOUT NOTICE

SECTION 2 - DESCRIPTION AND OPERATION

INTRODUCTION

The Plant Loop to Computer Interface (INPCI01) enables a host computer to interact with all nodes on an INFI 90 Plant Loop. The Plant Loop is a unidirectional serial data highway that all nodes (and other data users) share. The PCI provides an RS-232-C serial interface that links the Plant Loop to the host computer. This section covers the functional operation of the modules that make up the PCI.

INTERFACE OPERATION

The INPCI01 consists of three modules:

- Loop Interface Module (INLIM03)
- Point Table Module (INPTM01)
- Serial Interface Module (INSIM01)

These modules reside on a dedicated module bus. Figure 2-1 is a block diagram showing how each module functions as part of the interface.

Loop Interface Module INLIM03

The Loop Interface Module is the communication interface to the Plant Loop. The LIM sends and receives messages from

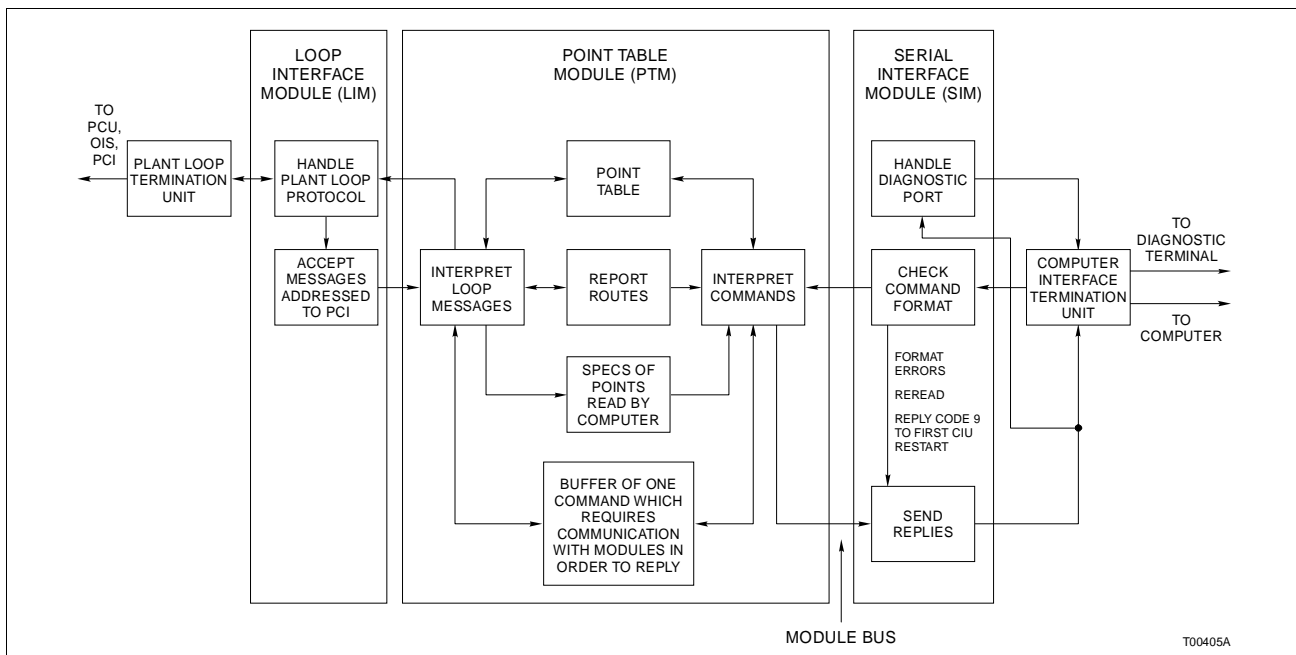

Figure 2-1. Functional Diagram of the INPCI01 Modules

other LIMs on the Plant Loop. LIMs can transmit and receive messages simultaneously at any time. There is no loop master or traffic director. LIM startup/shutdown is localized requiring no interaction with other LIMs on the loop. Each LIM receives all incoming messages and transmits a new stream of messages in a store and forward fashion to the next LIM.

The LIM can originate messages in its transmit buffer; however, messages usually come from the PTM. The LIM communicates directly with the PTM. It has access to the PTM memory through a direct memory access (DMA) cable. Besides sending messages from the PTM, the LIM informs the PTM when it successfully sends a message or discards a message destined for off-line nodes. The LIM can count events and errors (refer to Table 3-6 and 3-7) and display those counts on the faceplate LEDs.

Point Table Module INPTM01

The PTM interprets commands from the computer. The PTM can reply immediately to computer commands with information it stores in its point table. It also sends Plant Loop messages to the LIM and alters the point table when the computer wants to establish points not in the point table. Point tables store process inputs and outputs. Initially, the computer must establish a point in the table in terms of the PCU, module, block number and point type. Thereafter, the computer and interface pass data by point number. The computer may also read any process data from a PCU without using the point table.

The PTM interprets messages from the Plant Loop, stores any information belonging in the point table, and sends those messages to the SIM. The PTM acts as a buffer so that the communication speed of the computer (simple point-to-point protocol) doesn't interfere with the speed of the Plant Loop protocol.

Serial Interface Module INSIM01

This module directs the activity of the interface. It responds to commands issued by the computer. The SIM enables the computer to load INFI 90 modules with control strategies without affecting the point table. The computer sets station variables, mode and logic switches. It also reports values to modules and OISs configured to read them.

During normal operation, the SIM checks the format of the commands from the computer. It usually passes the commands to the PTM and repeats the PTM's reply to the computer. The SIM will reply directly to the computer without consulting the PTM if it detects format errors. It handles the diagnostic port by echoing every character received from the computer and repeating every reply.

SECTION 3 - INSTALLATION

INTRODUCTION

This section explains how to prepare the Plant Loop to Computer Interface (INPCI01) modules for installation. It covers handling procedures, switch settings for each module, termination unit/module and cable, and module installation. DO NOT attempt to operate the PCI before reading and completing the steps in this section.

SPECIAL HANDLING

The interface modules use CMOS devices. Follow the special handling procedures below:

NOTE: Always use Bailey's Field Static Kit (P/N 198385A2 - consists of wrist strap, ground cord assembly, and alligator clip) when working with modules. The kit is designed to connect a technician and the static dissipative work surface to the same ground point to prevent damage to the modules by electrostatic discharge.

1. Keep the modules in the special anti-static bag until you are ready to install them in the system. Save the bag for future use.
2. Ground the anti-static bag before opening.
3. Verify that all devices connected to the modules are properly grounded before using them.
4. Avoid touching the circuitry when handling the modules.

UNPACKING AND INSPECTION

1. Examine the modules immediately to verify that no damage has occurred in transit.
2. Notify the nearest Bailey Controls Sales Office of any damage.
3. File a claim for any damage with the transportation company that handled the shipment.
4. Use the original packing material and/or container to store the modules.
5. Store the modules in an environment of good air quality, and free from temperature and moisture extremes.

INSIM01 SWITCH SETTINGS

The Serial Interface Module (INSIM01), shown in Figure 3-1, has three user-configurable dipswitches and eight jumpers. These dipswitches and jumpers set the SIM operating options such as echo check, command and reply checksums, and port data characteristics. Refer to Tables 3-1 through 3-5 for option settings and set the dipswitches and jumpers for the desired operating characteristics.

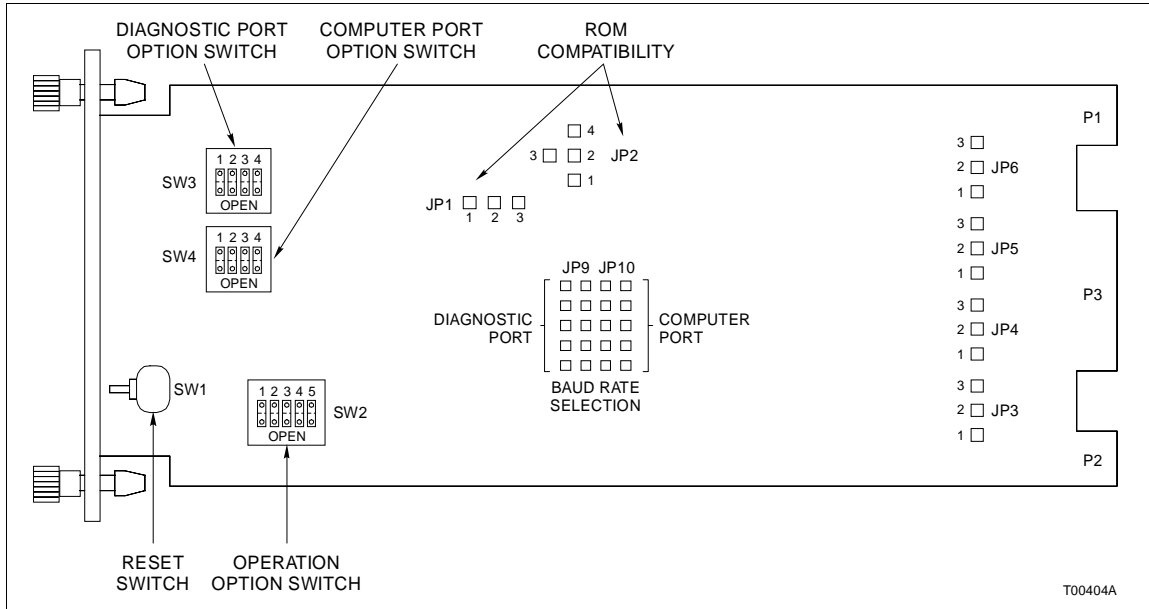

Figure 3-1. Switch and Jumper Locations on the SIM

Option Switch (SW2)

SW2 is a five position dipswitch that determines module operating options of the module. Table 3-1 lists the SW2 option settings. Record the SW2 settings in the space provided.

Table 3-1. Option Switch (SW2) Settings

Position	Setting	Function	User Setting
1	0	ROM self-checking enabled.	
	1	ROM self-checking disabled.	
2		Not used.	
3	0	Normal Operation.	
	1	Echo check.	
4		Not Used.	
5	0	Command and reply checksums enabled.	
	1	Command and reply checksums disabled.	

0 = Closed (on)
1 = Open (off)

Port Option Switch Settings (SW3 and SW4)

SW3 and SW4 are four position dipswitches that determine the data characteristics of the RS-232-C ports. Refer to Table 3-2 for diagnostic port data characteristic settings (SW3). Table 3-3 lists computer port data characteristics (SW4). Record the switch settings in the space provided.

Table 3-2. Diagnostic Port Options (SW3)

DATA CHARACTERISTICS						
SW3 Position				Number of Data Bits	Number of Stop Bits	Type of Parity
1	2	3	4			
	0	0	0	7	2	Even
	0	0	1	7	2	Odd
	0	1	0	7	1	Even
	0	1	1	7	1	Odd
	1	0	0	8	2	No
	1	0	1	8	1	No
	1	1	0	8	1	Even
	1	1	1	8	1	Odd

USER SETTING (SW3)						
SW3 Position				Number of Data Bits	Number of Stop Bits	Type of Parity
1	2	3	4			

1 = Closed (on)
0 = Open (off)

Table 3-3. Computer Port Options (SW4)

DATA CHARACTERISTICS							
Option	SW4 Position				Number of Data Bits	Number of Stop Bits	Type of Parity
	1	2	3	4			
Binary	0						
ASCII Text	1						
	0	0	0		7	2	Even
	0	0	1		7	2	Odd
	0	1	0		7	1	Even
	0	1	1		7	1	Odd
	1	0	0		8	2	No
	1	0	1		8	1	No
	1	1	0		8	1	Even
	1	1	1		8	1	Odd

DATA CHARACTERISTICS							
Option	SW4 Position				Number of Data Bits	Number of Stop Bits	Type of Parity
	1	2	3	4			

1 = Closed (on)
0 = Open (off)

ROM Jumpers

These jumpers enable the SIM to use ROM chips from different manufacturers. These jumpers must remain in their factory set position. Bailey service personnel will change them when installing firmware upgrades. Table 3-4 lists J1 and J2 jumper settings.

Table 3-4. ROM Compatibility (JP1 and JP2)

Jumper	ROM (4k or 8k)		
	2732	2532	2564/68764
JP1	1 to 2	2 to 3	2 to 3
JP2	1 to 2	2 to 3	2 to 4

NOTE: Short pins by inserting a jumper over them to enable option.

Bypass Options (JP3 to JP6)

These determine the RS-232-C handshaking signals on both ports. Install JP3 and JP5 so that the diagnostic terminal and computer do not need to supply Request to Send (RTS) signals. Table 3-5 lists the bypass option jumper settings. JP4 enables or disables the Data Terminal Ready (DTR) signal from the diagnostic terminal. Enable this option if the diagnostic terminal supplies a DTR or there is no diagnostic terminal installed. Disable this option if the diagnostic terminal does not provide a DTR signal. JP6 enables the DTR signal from the computer. Enable this option if the computer terminal supplies a DTR signal. Otherwise, JP6 should be disabled.

Table 3-5. Bypass Options

Bypass Option	Jumper Settings				
	JP3	JP4	JP5	JP6	User Setting
Not allowed	1 to 2				
Diagnostic terminal not required to provide RTS	2 to 3				
Enable DTR from diagnostic terminal to PCI		1 to 2			
Disable DTR from diagnostic terminal to PCI		1 to 2			
Not allowed			1 to 2		
Computer not required to provide RTS			2 to 3		
Enable DTR from computer to PCI				1 to 2	
Disable DTR from computer to PCI				2 to 3	

NOTE: Short pins by inserting a jumper over them to enable option.

Communication Rate (JP9 and JP10)

Set the communication rate of each RS-232-C port. Figure 3-2 shows the jumper settings for the available communication rates. Install a jumper on JP9 to set the communication rate for the diagnostic terminal. Install a jumper on JP10 to set the communication rate for the computer terminal.

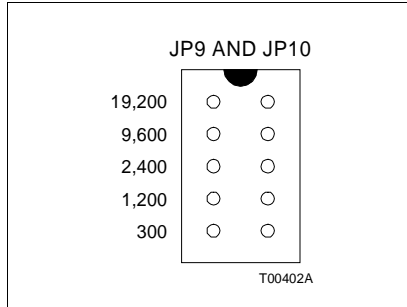

Figure 3-2. Jumper Settings for Communication Rates

INLIM03 SWITCH SETTINGS

The Loop Interface Module (INLIM03), shown in Figure 3-3, has two user-configurable dipswitches: Event/Error Counter Address Switch SW1 and Address Switch SW2. Tables 3-6 and 3-7 list the switch settings for the Event and Error Counters. The LIM faceplate LEDs display the contents of the event/error counters. Switch SW2 poles 1 and 2 are CLOSED for normal operation. Refer to Table 3-8 for SW2 settings. The LIM can have any address from 1 to 63.

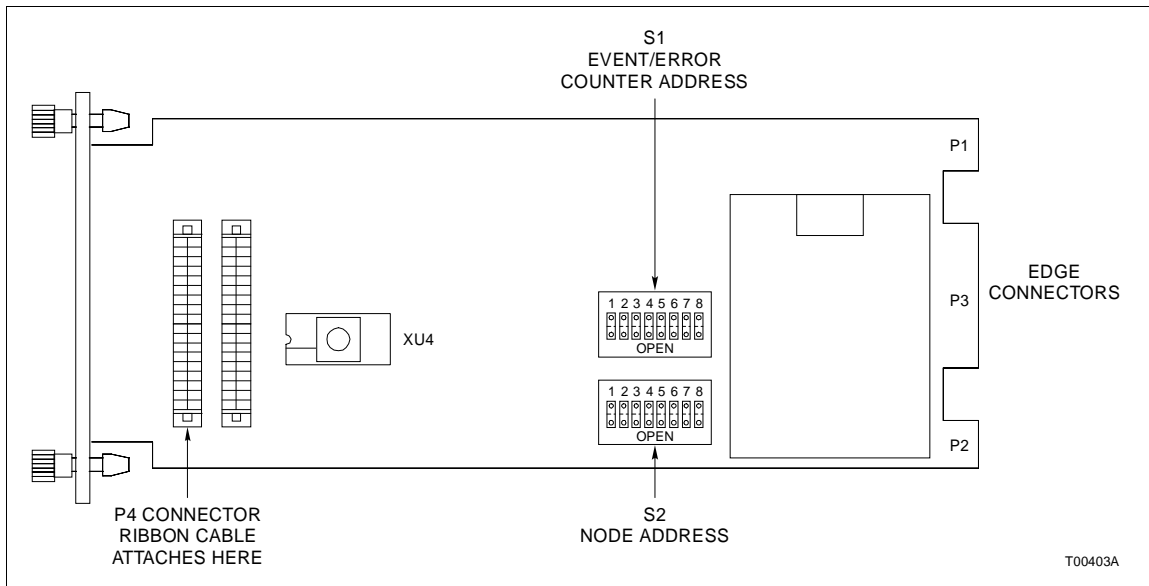

Figure 3-3. LIM Switch Locations

Table 3-6. LIM Event Counter Addresses (SW1)

Counter Address	Hex Address	Switch Position								Description	User Setting
		1	2	3	4	5	6	7	8		
48	30	0	0	1	1	0	0	0	0	Total messages transmitted, including forwarding.	
49	31	0	0	1	1	0	0	0	1	Transmit retries.	
50	32	0	0	1	1	0	0	1	0	Composite PTM Receive/ Transmit, 4 bits each. Receive is viewed at the top LED.	
51	33	0	0	1	1	0	0	1	1	Messages taken from the PTM transmit buffer.	
52	34	0	0	1	1	0	1	0	0	Messages stored in PTM receive buffer.	
53	35	0	0	1	1	0	1	0	1	Interrupt Requests (IRQs) sent by PTM.	
54	36	0	0	1	1	0	1	1	0	High Priority (HP) messages transmitted.	
55	37	0	0	1	1	0	1	1	1	High Priority messages received.	
56	38	0	0	1	1	1	0	0	0	Commands issued by the PTM.	
57	39	0	0	1	1	1	0	0	1	Missed PTM transmit requests.	
58	3A	0	0	1	1	1	0	1	0	Spurious Non-Maskable Interrupts (NMI) caused by address present.	
59	3B	0	0	1	1	1	0	1	1	HEY (request for an interrupt; generated by PTM) message sent.	
60	3C	0	0	1	1	1	1	0	0	Messages discarded when the destination is off-line.	
61	3D	0	0	1	1	1	1	0	1	HEY time expirations.	
62	3E	0	0	1	1	1	1	1	0	Passes through the IDLE level (2 bytes wide).	

0 = Closed (on)
1 = Open (off)

Table 3-7. LIM Error Counter Addresses (SW1)

Counter Address	Hex Address	Switch Position								Description	User Setting
		1	2	3	4	5	6	7	8		
64	40	0	1	0	0	0	0	0	0	Composite error count developed everyhandshake period - the summation of all other error counters.	
65	41	0	1	0	0	0	0	0	1	Unresolved NMI interrupts.	
66	42	0	1	0	0	0	0	1	0	Unresolved IRQ interrupts.	
67	43	0	1	0	0	0	0	1	1	Unresolved timer interrupts.	

Table 3-7. LIM Error Counter Addresses (SW1) (continued)

Counter Address	Hex Address	Switch Position								Description	User Setting
		1	2	3	4	5	6	7	8		
68	44	0	1	0	0	0	1	0	0	Queue overflow message losses.	
69	45	0	1	0	0	0	1	0	1	Checksum failures.	
70	46	0	1	0	0	0	1	1	0	Unresolved PTM IRQs.	
71	47	0	1	0	0	0	1	1	1	Sequence errors.	
72	48	0	1	0	0	1	0	0	0	Header CRC/OVRN errors.	
73	49	0	1	0	0	1	0	0	1	Data CRC/OVRN errors.	
74	4A	0	1	0	0	1	0	1	0	Messages developing data CRC errors on route to destination.	
75	4B	0	1	0	0	1	0	1	1	Transmission failures.	
76	4C	0	1	0	0	1	1	0	0	Watchdog timer expirations.	
77	4D	0	1	0	0	1	1	0	1	Data length errors.	
78	4E	0	1	0	0	1	1	1	0	Loop - 1 Receive (RCV) failure.	
79	4F	0	1	0	0	1	1	1	1	Loop - 2 Receive (RCV) failure.	
80	50	0	1	0	1	0	0	0	0	Loop - 1 Transmit (TX) failure.	
81	51	0	1	0	1	0	0	0	1	Loop - 2 Transmit (TX) failure.	

0 = Closed (on)
1 = Open (off)

Table 3-8. LIM Node Address Setting (SW2)

EXAMPLE SETTINGS									
Address Example	Switch Position	1	2	3	4	5	6	7	8
	Binary Value	128	64	32	16	8	4	2	1
1		0	0	0	0	0	0	0	1
9		0	0	0	0	1	0	0	1
63		0	0	1	1	1	1	1	1

USER SETTING (SW2)									
User Address	Switch Position	1	2	3	4	5	6	7	8
	Binary Value	128	64	32	16	8	4	2	1

0 = Closed (on)
1 = Open (off)

INPTM01 SWITCH SETTINGS

The Point Table Module (INPTM01), shown in Figure 3-4, has one user-configured dipswitch (SW1). SW1 enables module diagnostics. Refer to Table 3-9 and set SW1 for normal operation.

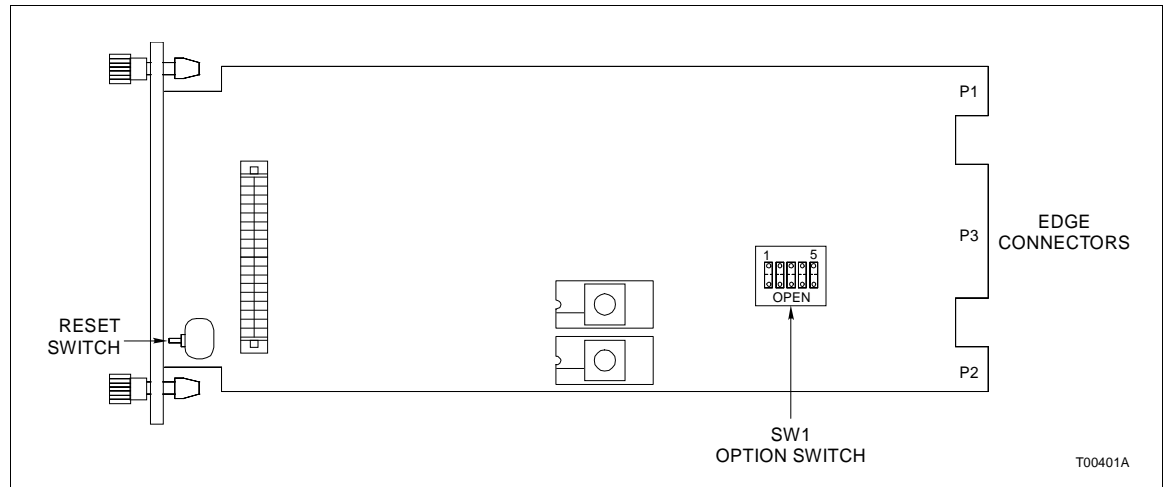

Figure 3-4. PTM Switch (SW1) Location

Table 3-9. PTM Options (SW1)

Switch Position					Function	User Setting
1	2	3	4	5		
0	0	0	0	0	Normal operation.	
0	0	0	1	0	Normal PTM operation without catastrophic error checking (for Test Purposes ONLY)	
0	0	1	0	0	RAM test mode. If Status LED turns red, the module has Failed the test.	
0	0	1	1	0	ROM test mode. If Status LED turns red, the module has failed the test.	
0	1	0	0	0	Execute Interrupt Request (IRQ) LIM handshake diagnostic. Used in combination with the LIM off-line diagnostics.	

0 = Closed (on)
1 = Open (off)

TERMINATION UNIT (MODULE) CONFIGURATION AND INSTALLATION

Two of the interface modules (INLIM03, INSIM01) require termination. The INSIM01 terminates with the NTCU01. The INLIM03 terminates with the NTCL01 or NICL01. Appendices **A** and **B** contain dipshunt configuration information for the NTCL01 and NICL01. There are no dipshunts on the NTCU01. Refer to the Termination Instructions, I-E96-408 (NICL01) or I-E96-422 (NTCL01), for complete information about installing the termination module or unit.

NOTE: Use a standard RS-232-C cable with DB-25 connectors when connecting the computer or terminal to the NTCU01.

INSTALLING THE INTERFACE MODULES

If the switch settings on the interface modules are complete, they are ready to be installed in the Module Mounting Unit (MMU).

Installing the INSIM01

To install the SIM:

1. Verify the SIM slot assignment in the MMU.

WARNING

Disconnect power before installing dipshunts for slave modules on the MMU backplane (slave expander bus). Failure to do so could result in severe or fatal shock.

AVERTISSEMENT

Couper l'alimentation avant d'installer les dipshunts sur la plaque arriere du chassis de montage de modules (MMU). Toute negligence a cet egard constitue un risque de choc pouvant entrainer des blessures graves, voire mortelles.

2. Attach the hooded end of the cable (NTKU01 for the NTCU01) to the MMU backplane cable connector opening for the SIM. The other end of the cable attaches to the termination unit.
3. Guide the top and bottom edges of the circuit card along the top and bottom rails of MMU.
4. Slide the module into the slot; push the module until the front panel is flush with the top and bottom of the MMU frame.
5. Turn the two captive latches a half turn to lock the module in place.

Installing the INLIM03 and INPTM01

The LIM and PTM should be installed as a pair in adjacent slots. To install the LIM/PTM:

1. Verify the MMU slot assignments for the modules.
2. Attach the hooded end of the cable (NKLS03 for NTCL01; NKLS04 for the NICL01) to the MMU backplane cable connector opening for the LIM. The other end of the cable attaches to the termination unit or TMU backplane.
3. Connect one end of the Bailey supplied ribbon cable (DMA cable) to the P4 connector on the LIM. Connect the other end of the DMA cable to the P4 connector on the PTM (see Figures 3-2 and 3-3).
4. Guide the top and bottom edges of both circuit cards along the top and bottom rails of adjacent slots in the MMU.
5. Slide the modules into the slot; push the modules until the front panels are flush with the top and bottom of the MMU frame.
6. Turn the two captive latches a half turn to lock the module in place.

SECTION 4 - OPERATING PROCEDURES

INTRODUCTION

This section explains how to place the INPCI01 in operation. It covers the use of module faceplate LEDs and controls.

INTERFACE START-UP

The interface is ready for normal operation upon installation. Start up the interface by issuing a RESTART command through the computer. Refer to the Enhanced CIU Programmer's Guide for information about interface commands. Initially, there are no points established in the point table and the loop is bypassed until the computer gives the PCI the proper sequence of commands. Once the PCI receives this sequence of commands, the other nodes on the Plant Loop see it as an executing node.

SERIAL INTERFACE MODULE LEDs

The SIM faceplate has a set of four LEDs that count computer commands and replies during normal operation (see Figure 4-1). These LEDs go through an exercise sequence and memory test before normal operation begins (see Figure 4-2).

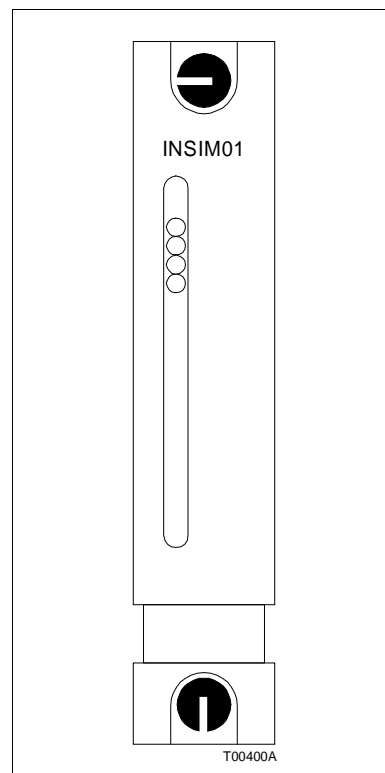

Figure 4-1. SIM Faceplate

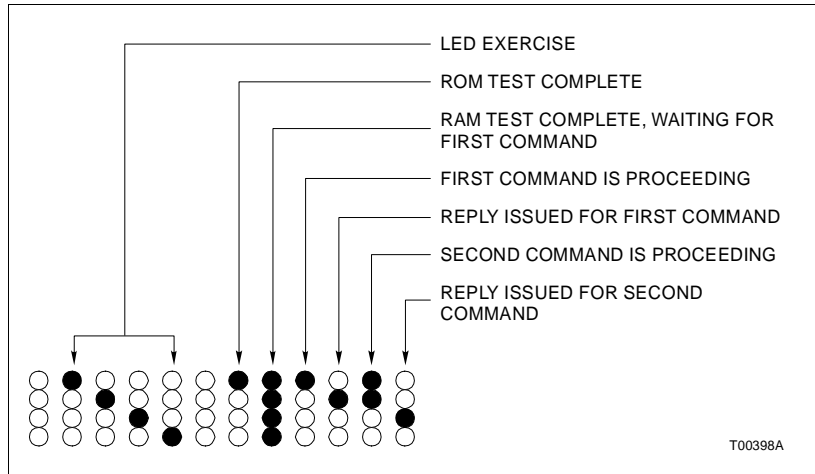

Figure 4-2. SIM LED Sequence

LOOP INTERFACE MODULE LEDs

There are eight LEDs on the LIM faceplate (see Figure 4-3). These LEDs display the contents of event and error counters, and pass/fail information when on-board diagnostics are run (refer to Tables 3-6 and 3-7 for a list of event and error counter codes).

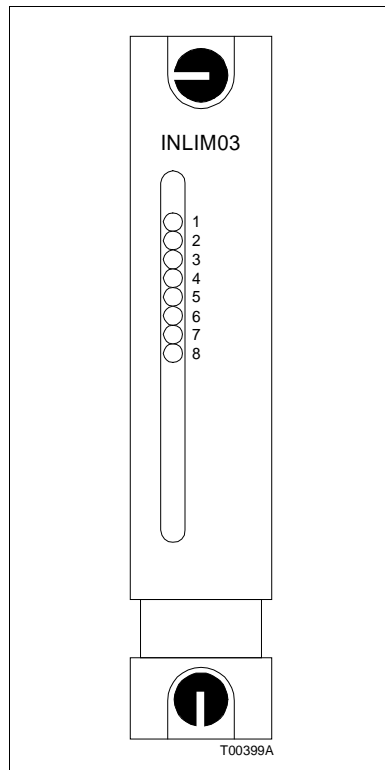

Figure 4-3. LIM Faceplate

POINT TABLE MODULE LED

The Point Table Module has one red/green LED that displays the module's operating condition (see Figure 4-4). The PTM status LED has three possible states. Refer to Table 4-1 for PTM status LED states and their meaning.

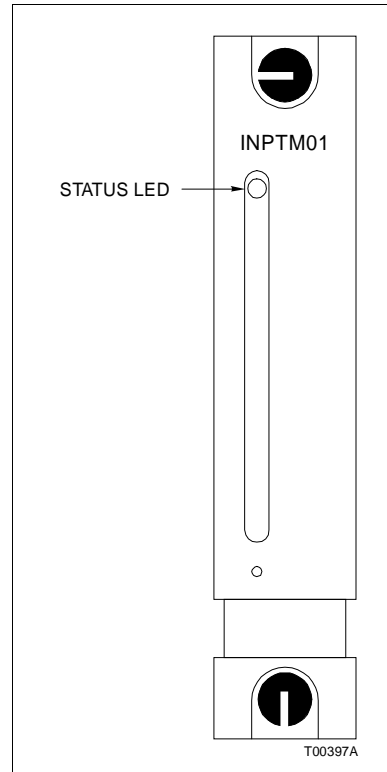

Figure 4-4. PTM Faceplate

Table 4-1. PTM Status LEDs States

LED States	Meaning
Off	No power to the PTM.
Solid Green	Normal operation.
Solid Red	PTM hardware failure.

SECTION 5 - TROUBLESHOOTING

INTRODUCTION

There are several ways to troubleshoot problems with the interface while it is operating. They include using the Loop Interface Module (INLIM03) error counters, accessing module status bytes through the host computer, using the diagnostic port, and doing a simple checkout procedure that tests the interface without involving the host computer

EVENT AND ERROR COUNTERS

The LIM provides error counters to assist in diagnosing problems. The LIM option switch (S1) sets the address of the error counter that displays a count on the LIM faceplate LEDs. Refer to Table 3-7 for a list of error counters. Information from an error counter is similar to an event counter, except that it represents events caused by hard errors.

MODULE STATUS BYTES

Five status bytes provide information about Plant Loop to Computer Interface module status. Refer to the Enhanced CIU Programmer's Reference Manual for a list of module status bytes, their meaning and how to access this information on the host computer.

DIAGNOSTIC TERMINAL

Use the diagnostic terminal to monitor interface to computer communication. The diagnostic port works when the interface is in normal operation (not in the echo mode). The interface displays each command it receives and its reply on the diagnostic port in this format:

C hh hh hh OD
R hh hh hh OD

The *C* denotes the start of a command received from the computer. The *R* denotes the start of the reply sent to the computer for the previous command. The *hh* is the hexadecimal representation of the bytes involved in the transmission. The diagnostic port displays the transmitted version of the reply or command. That is, hexadecimal 1B 0E is transmitted for hexadecimal 0D and 1B 1B is transmitted for 1B. For computers using the X-ON, X-OFF option, these bytes will be inserted in

the reply display. These error codes are displayed in place of the byte when the respective error condition occurs:

- *P - parity error
- *F - framing error
- *O - overrun error
- *D - data carrier detect error
- *L - bytes lost by the diagnostic port but not lost by the interface normal operation

The interface does not allow the diagnostic port to degrade the performance of the normal interface and host computer operation. Because of this, the diagnostic port can lose information which the interface is correctly processing, particularly if the diagnostic port is set to a slow communication rate. The *L error code indicates this condition. When this happens, the interface stops displaying the rest of the command reply. It discards intervening commands and replies which it does not have time to display. It then continues the display with the beginning of the next command. Enter **Ctrl-S** to suspend the diagnostic port dump for examination. The display stops updating while it is suspended.

Press **Ctrl-S** again to unsuspend. While the display is suspended, the diagnostic port continues to store information. So, if it loses characters because of the suspension the *L code will appear some time after the unsusension.

The diagnostic port is always active and may be used by cabling a terminal to it, matching the selected baud rate, data transmission characteristics, and selecting normal operation (SIM option).

ECHO TEST

This test provides a simple means of testing the computer to interface connections. Enable this test by setting the SIM option switch (SW2), position 3, to 1. When the SIM executes in this mode, the SIM LEDs go through their normal exercise routine, ROM test and RAM test as in normal operation. Then they display a count of characters input to the SIM in the echo mode.

To use this feature, cable a terminal to the port being tested using a standard RS-232-C cable. The port data characteristics and communication rate of the terminal must be set to match those settings on the SIM.

The SIM echoes characters entered on the terminal keyboard. Those characters appear on the terminal screen. If the SIM finds any framing or parity errors, it will not echo that charac-

ter. The SIM LEDs keep a count of the characters with or without errors. In this manner, check each port for correct sending and receiving operation at any communication rate or port data characteristic.

INTERFACE CHECKOUT PROCEDURE

This procedure tests the interface without involving the host computer. This test requires the use of a terminal on the computer port. To do the interface checkout procedure:

1. Connect the terminal to the computer port (port 0) of the NTCU01. The DB-25 connector from the terminal should have pins 2 through 8 and pin 20 connected to pins 2 through eight and pin 20 of the TCU connector.
2. Set the communication rate and port data characteristics of the terminal to match the option settings on the SIM.
3. Set the terminal to half duplex so characters entered on the key board will be displayed on the terminal screen. The interface should not echo the characters as it normally would with the computer installed.
4. Remove the SIM from the module mounting unit and set it to ASCII (SW4, position 1 = 1, open).
5. Disable the command and reply checksums option (SW4, position 5 = 1, open).
6. The SIM should be set for normal operation (SW4, position 3 = 0, closed).
7. Insert the SIM into its module mounting unit slot. The SIM LEDs should go through their normal sequence (see Figure 4-1).
8. Type:

AU000

The interface should reply with a 009 and the terminal reads:

009000

This means the interface needs a second restart command as explained in the Enhanced CIU Programmer's Reference Manual.

9. Type:

AU000

This is the full interface restart command. The interface should reply with a 000 and the terminal reads:

000000000002

The LIM is out of bypass and the LIM LEDs may begin counting messages from other nodes on the Plant Loop.

10. Read a module status to verify that there is communication between the interface and a module.

11. Find a working module and type:

BC000pppppmmmmm

where ppppp is the five digit PCU number and mmmmm is the five digit module number.

These numbers are decimal numbers. For example, to read PCU 11, module 22 type:

BC0000001100022

12. The module replies and the terminal displays an 18 digit reply code. For example:

000101000000000000

where the first three digits 000 indicate no error followed by five sets of three digits that represent the decimal value of the module's status bytes. In this example, the second set of digits 101 translates into hexadecimal 65 which indicates an executing COM module. Refer to the Enhanced CIU Programmer's Manual for more information about module status bytes.

13. If the interface can communicate with a module and the module replies, the interface checks good.

14. Remove the SIM from the MMU and set it to binary (SW4, position 1 = 0, closed) and enable the command and reply checksum option if desired.

15. Remove the terminal and connect the computer to the computer port (port 0) of the NTCU01.

Table 5-1. LIM Edge Connector P3 Pin Assignments

Pin No.	Signal	Pin No.	Signal
1	Loop 2 In (+)	13	Loop 2 Bypass Control
2	Loop 2 In (-)	14	Cable Shield
3	Cable Shield	A	Cable Shield
4	Loop 1 Out (+)	D	Loop 1 Out (-)
5	Loop 1 Out (+)	E	Loop 1 Out (-)
6	Loop 1 In (+)	F	Cable Shield
7	Loop 1 In (-)	H	Loop 2 Bypass Control
8	Cable Shield	K	Loop 2 Out (-)
9	Loop 2 Out (+)	L	Loop 2 Out (-)
10	Loop 2 Out (+)	M	Cable Shield
11	Cable Shield	S	Cable Shield

Table 5-2. PTM Edge Connector P1 Pin Assignments

Pin No.	Signal	Pin No.	Signal
1	+5 VDC	2	+5 VDC
3	N/C	4	N/C
5	Common	6	Common
7	+15 VDC	8	-15 VDC
9	Power Fail Interrupt	10	Power Fail Interrupt
11	Module Bus	12	Module Bus

Table 5-3. SIM Board Edge Connector P3 Pin Assignments

Pin No.	Signal	Pin No.	Signal
7	Signal Ground	H	Receive Data
9	Signal Ground	K	Transmit Data
11	Signal Ground	M	Clear to Send
13	Signal Ground	P	Request to Send
15	Signal Ground	S	Data Terminal Ready

SECTION 6 - MAINTENANCE

INTRODUCTION

The Plant Loop to Computer Interface (INPCI01) requires minimal maintenance. The following maintenance schedule will ensure trouble free service.

NOTE: Only qualified personnel should perform maintenance.

MAINTENANCE SCHEDULE

The PCI maintenance schedule is shown in Table 6-1. Perform these tasks at the specified intervals.

Table 6-1. Maintenance Schedule

Task	Interval
Clean and check all cable connections to the INLIM03, INPTM01 and INSIM01.	Every 6 months or during plant shutdown, whichever occurs first.
Use a static vacuum cleaner to remove dust from: Modules Module Mounting Unit Fan Assembly Power Entry Panel	Every 6 months or during plant shutdown, whichever occurs first.

SECTION 7 - REPAIR/REPLACEMENT PROCEDURES

INTRODUCTION

This section explains the replacement procedures for the Plant Loop to Computer Interface (INPCI01). There are no special tools required to replace an interface module.

NOTE: Always use the Bailey Field Static Kit (P/N 1948385A1) when working with the interface modules. This kit connects the static dissipative work surface and technician to the same ground point.

MODULE REPAIR/REPLACEMENT

If you determine an interface module is faulty, replace it with a new one. **DO NOT** try to repair the module; replacing components may affect the module performance. You can remove the module while system power is supplied. To replace a module:

1. Push and turn the two front panel captive retaining latches one half turn to unlatch the module. It is unlatched when the slots on the latches are vertical and the open end of the slots face away from the module.
2. Gently slide the module out of the MMU.
3. Configure the replacement module switch and jumper settings. Ensure they are set the same as the original module.
4. In the same slot assignment as the original module, align the replacement module with the plastic guide rails in the MMU; gently slide it in until the front panel is flush with the top and bottom of the MMU frame.
5. Push and turn the two captive retaining latches on the module faceplate one half turn to the latched position. It is latched when the slots on the latches are vertical and the open ends face the center of the module.
6. Return to normal operation.

SECTION 8 - SUPPORT SERVICES

INTRODUCTION

Bailey Controls is ready to assist in the use of its products. Requests for sales, applications services, installation, repair, overhaul and maintenance contract services should be made to the nearest sales office.

REPLACEMENT PARTS AND ORDERING INFORMATION

If you are making repairs at your own facility, replacement parts should be ordered through a Bailey sales office. Provide the following information for parts orders:

1. Part description, part number and quantity.
2. Model, serial number (if applicable) and ratings of the assembly containing the ordered part.
3. Bailey publication number and reference used in identifying the part.

When ordering standard parts from Bailey Controls, use the part number and description from the Replacement Parts section of the manual. Parts not having a commercial description in the Replacement Parts section must be ordered from a Bailey Controls sales office.

TRAINING

Bailey Controls has a modern training facility equipped to provide service and repair instructions. This facility is available for in-plant training of your personnel. Contact a Bailey Controls sales office for information on available classes and scheduling.

TECHNICAL DOCUMENTATION

You can obtain additional copies of this manual through the nearest Bailey sales office. Copies, over and above those provided with the original purchase, are available at a minimum charge to the customer. Contact a Bailey Controls sales office for information.

APPENDIX A - TERMINATION UNIT (NTCL01) CONFIGURATION

INTRODUCTION

The INLIM03 uses the NTCL01 for termination. Table A-1 and A-2 list the terminal assignments for the loop input/output connections. Table A-3 provides jumper settings associated with cable type. Figure A-1 shows twinax cable connections for the NTCL01.

NOTE: Twinax cables connect to the terminals. Coax cables connect to the BNC connectors.

Table A-1. NTCL01 Terminal Assignments

TB1	Assignments	TB3	Assignments
1	Loop 1 In, +	1	Loop 2 In, +
2	Loop 1 In, -	2	Loop 2 In, -
3	Loop 1 In, Shield	3	Loop 2 In, Shield
4	No Connection	4	No Connection
5	Loop 1 Out, +	5	Loop 2 Out, +
6	Loop 1 Out, -	6	Loop 2 Out, -
7	Loop 1 Out, Shield	7	Loop 2 Out, Shield
8	Power System Status 1	8	Power System Status 2

Table A-2. NTCL01 BNC Assignments

BNC	Assignments	BNC	Assignments
J1	Loop 1 In	J8	Loop 2 In
J2	Loop 1 Out	J9	Loop 2 Out

Table A-3. Jumper Settings and Cable Types

NLIM03		
JUMPER NO.	TWINAX	COAX
J3, J10		
J4-J7, J11-J14		
J15-J18		

POST NUMBERS	1	2	3

T00365A

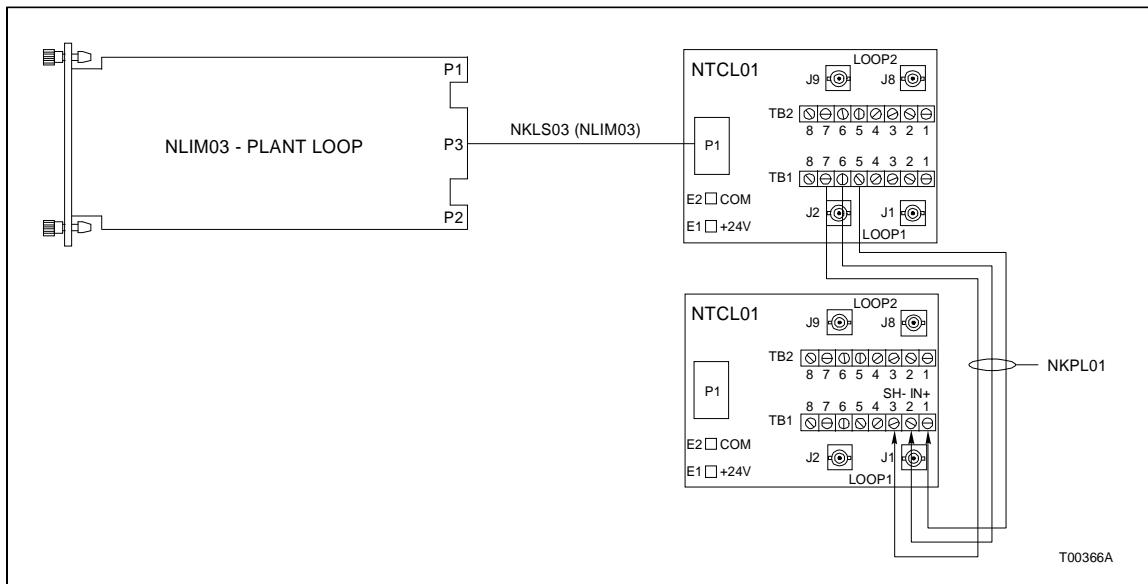

Figure A-1. NTCL01 Termination Unit and Terminal Assignments

APPENDIX B - TERMINATION MODULE (NICL01) CONFIGURATION

INTRODUCTION

The INLIM03 can use the NICL01 for termination. Tables B-1 and B-2 list the terminal assignments for the loop input/output connections. Table B-3 provides jumper settings associated with cable type. Figure B-1 shows twinax cable connections for NICL01.

NOTE: Twinax cables connect to the terminals. Coax cables connect to the BNC connector.

Table B-1. NICL01 Terminal Assignments

TB1	Assignments	TB2	Assignments	TB3	Assignments
1	Ground	4	Power System Status 1	25	Loop 1 Out, Shield
2	Common	5	Power System Status 2	26	Loop 1 Out, -
3	+ 24 VDC	6	Loop 2 In, +	27	Loop 1 Out, +
		7	Loop 2 In, -	28	Loop 1 In, Shield
		8	Loop 2 In, Shield	29	Loop 1 In, -
		9	Loop 2 Out, +	30	Loop 1 In, +
		10	Loop 2 Out, -	31	no connection
		11	Loop 2 Out, Shield	32	no connection

Table B-2. NICL01 BNC Assignments

BNC	Assignments	BNC	Assignments
J1	Loop 1 In	J8	Loop 2 In
J2	Loop 1 Out	J9	Loop 2 Out

CAUTION

Ensure that the end marked J1 is connected to P1 on the NICL01, and J2 is connected to the LIM. Failure to do so could result in module damage (see Figure B-1).

ATTENTION

S'assurez que l'extrémité identifiée par J1 est reliée à P1 du module NICL01 et que J2 est reliée au module LIM. Sinon, les modules pourraient être endommagés (voir la figure B-1).

Table B-3. Jumper Settings and Cable Types

NLIM03		
JUMPER NO.	TWINAX	COAX
J3, J10		
J4-J7, J11-J14		
J15-J18		

POST	1	2	3
NUMBERS			

T00365A

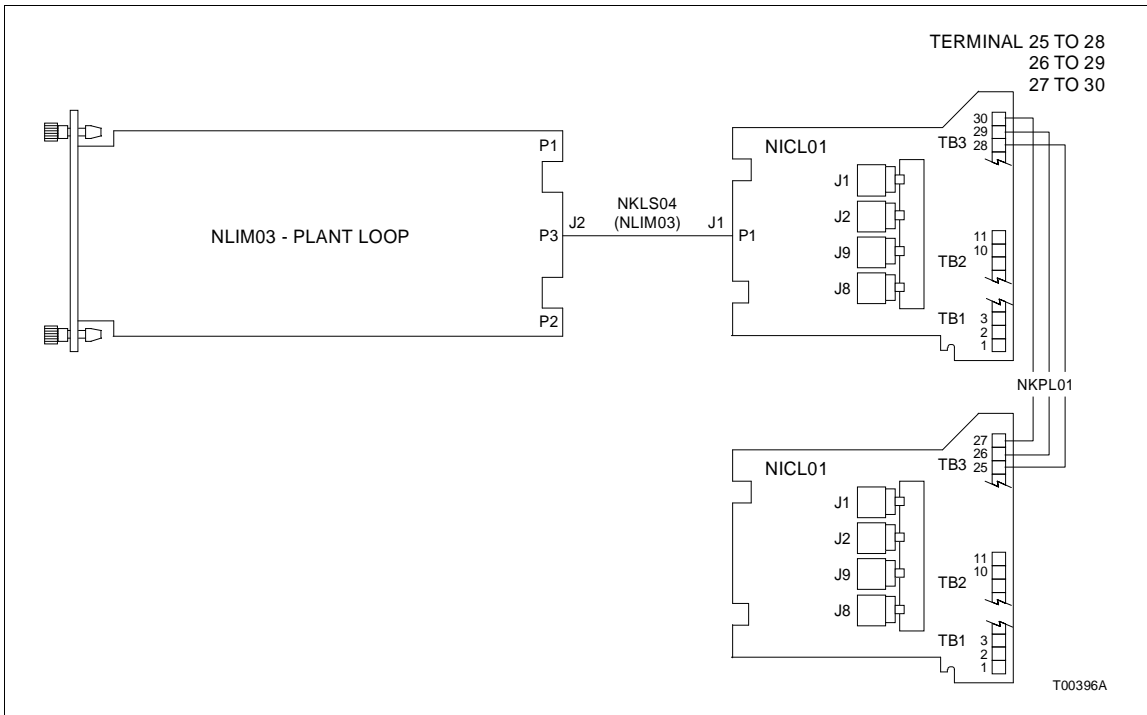

Figure B-1. Typical Twinx Cable Connection for the NICL01

Visit Elsasg Bailey on the World Wide Web at <http://www.bailey.com>

Our worldwide staff of professionals is ready to meet *your* needs for process automation.
For the location nearest you, please contact the appropriate regional office.

AMERICAS

29801 Euclid Avenue
Wickliffe, Ohio USA 44092
Telephone 1-216-585-8500
Telefax 1-216-585-8756

ASIA/PACIFIC

152 Beach Road
Gateway East #20-04
Singapore 189721
Telephone 65-391-0800
Telefax 65-292-9011

EUROPE, AFRICA, MIDDLE EAST

Via Puccini 2
16154 Genoa, Italy
Telephone 39-10-6582-943
Telefax 39-10-6582-941

GERMANY

Graefstrasse 97
D-60487 Frankfurt Main
Germany
Telephone 49-69-799-0
Telefax 49-69-799-2406